

No Drill Front License Plate Bracket Install Toyota GR Corolla

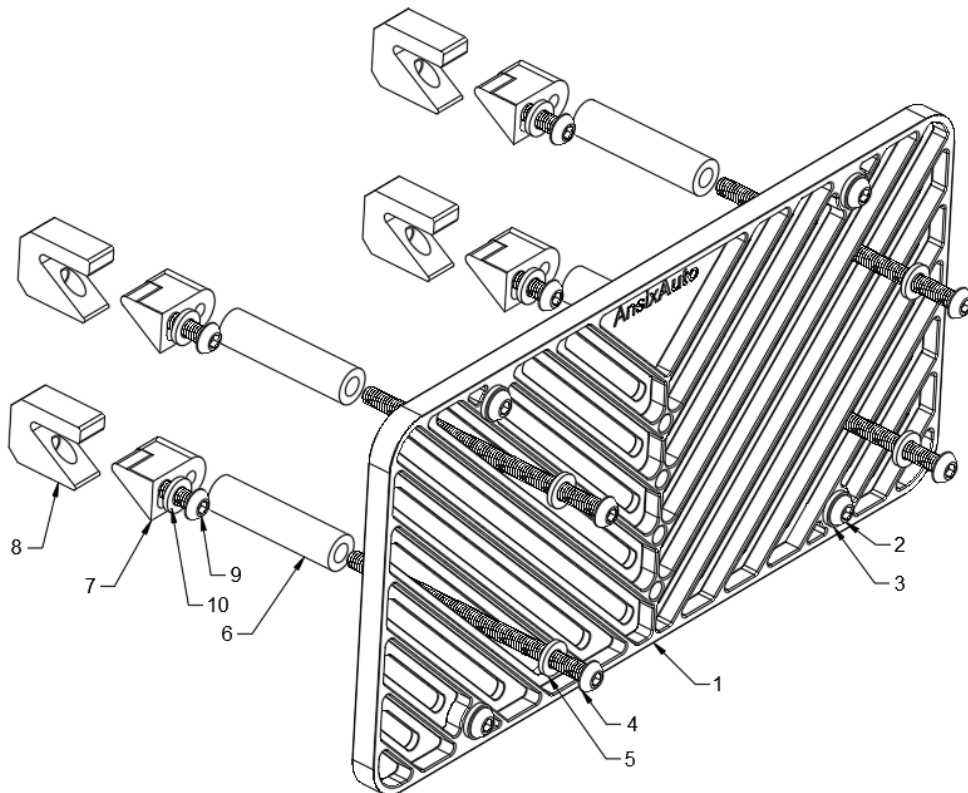

Included Parts:

1. Plate Bracket
2. M6x12 button head cap screw (4)
3. M6 Washer (12)
4. M6 x 30mm button head cap screw (4)
5. M6 Washer (12)
6. Spacer [12mm] (4)
7. Wedge mount (4)
8. Wedge clamp (4)
9. M6x30mm button head cap screws(2)
10. M6 Washer (12)

Install Procedure:

1. Assemble the wedge clamps components [7] and [8] using the 30mm long M6 cap screws [9], and M6 washers [10] as shown in the diagram



2. Clamp all four wedge clamp assemblies to the grille. Refer to the above photo for a reference for the positioning.



3. Pass the M6 screw [4] through the M6 washer [5] then through the desired slot in the Plate Bracket [1]. See photo above for a reference for which slot and positioning was used. Stack the spacer(s) [6] onto the cap screw and thread it into the wedge mounts [7]. Repeat for all four positions.
4. Align and tighten all the cap screws to give the desired position on the bumper. This may take a few tries to get perfectly centered. The position of the wedge clamps may need to be adjusted.
5. Fasten the license plate to the Plate Bracket [1] with the four M6x12 Socket Head Cap Screw [2] and M6 Washer [3].

If desired, you may adjust the position of the license plate by changing the positioning of the clamps and the slot position used on the plate bracket. The license plate can be moved higher or lower or even off to the side depending on your preference. The instructions above provide a starting point on where we recommend the license plate to be positioned.