

No Drill Front License Plate Bracket Install Honda Civic Type R FL5 2023+

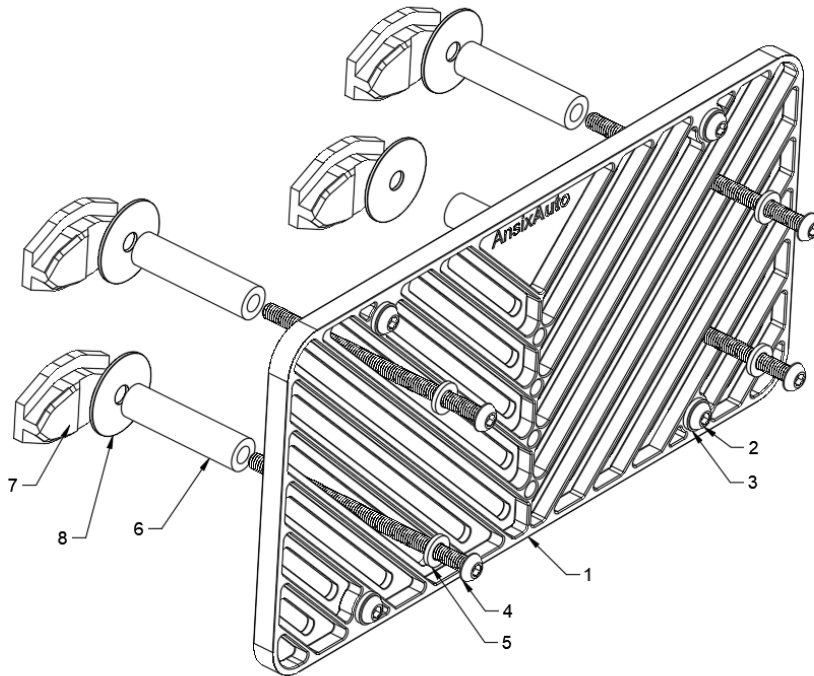

Included Parts:

1. Plate Bracket
2. M6x12 button head cap screw (4)
3. M6 Washer (8)
4. M6 x 30mm button head cap screw (4)
5. M6 Washer (8)
6. 6mm thick spacer (2)
7. FL5 Grille Nut (4)
8. M6 Fender Washer (4)

Install Procedure:

1. Attach some string and tape to all 4 FL5 Grille Nuts [7]. The string is to retrieve the Grille Nut in case it gets dropped behind the grille.



2. Feed each grille nut through the grille at the desired grille location. Use the above photo as a reference to where the nuts may be used. Ensure that all four threaded holes in the grille nuts line up with the slots in the license plate bracket. This is just a guideline as they can be used in other locations and orientations to place the license plate in a different position.
3. Pass the M6x30 Socket Head Cap Screw [4] through the Plate Bracket [1] via the desired slot. Then feed the screw through the Spacer [6] and M6 Fender Washer [8]. Fasten the screw into the FK8 Grille Nut [7].
4. Repeat step 3 for all 4 mounting locations.
5. Fasten the license plate to the Plate Bracket [1] with the four M6x12 Socket Head Cap Screw [4] and M6 Washer [5].

If desired, you may adjust the position of the license plate by changing the positioning of the nuts and the slot position used on the plate bracket. The license plate can be moved higher or lower or even off to the side depending on your preference. The instructions above provide a starting point on where we recommend the license plate to be positioned.